

XC6500

XC SERIES Commercial Portable Generator

Model G0080430 UPC: 696471102901
(49-State)

Features

- **COsense® Technology** – STOPS, ALERTS, SAVES. Powerful protection against hazardous carbon monoxide.
- **X Frame - fully wrapped, heavy duty 12 gauge steel tube** provides rugged durability and protects the generator and fuel tank from damage.
- **Steel lifting pocket** designed for easier lifting and transportation on jobsites by crane or forklift.
- **Generac G-Force engine** features Best-in-Class power with full pressure lubrication and is optimized for generator use.
- **Impact resistant fuel tank design** recessed tank edges reduce damage when transported by forklift.
- **Full panel GFCI protection** OSHA compliant with covered outlets to protect from the elements.
- **Easy access to all routine maintenance areas** including filters and spark plugs; no need to remove fuel tank or side panels.
- **Never flat wheels with steel hubs** makes movement around the jobsite easy and efficient.
- **Protected axle** integrated into frame, shields from impact during transport.
- **Welded steel feet** reinforced for superior durability.
- **Fold-down locking handles** feature one-handed locking mechanism for easy storage.
- **Engraving plate** allows unit to be tagged / cataloged for use in contractor and rental fleets.
- **TruePower™ Technology** provides clean, smooth operation of sensitive electronics, tools, and appliances.



AC Rated Output Running Watts 6500
AC Maximum Output Starting Watts 8125

Control Panel

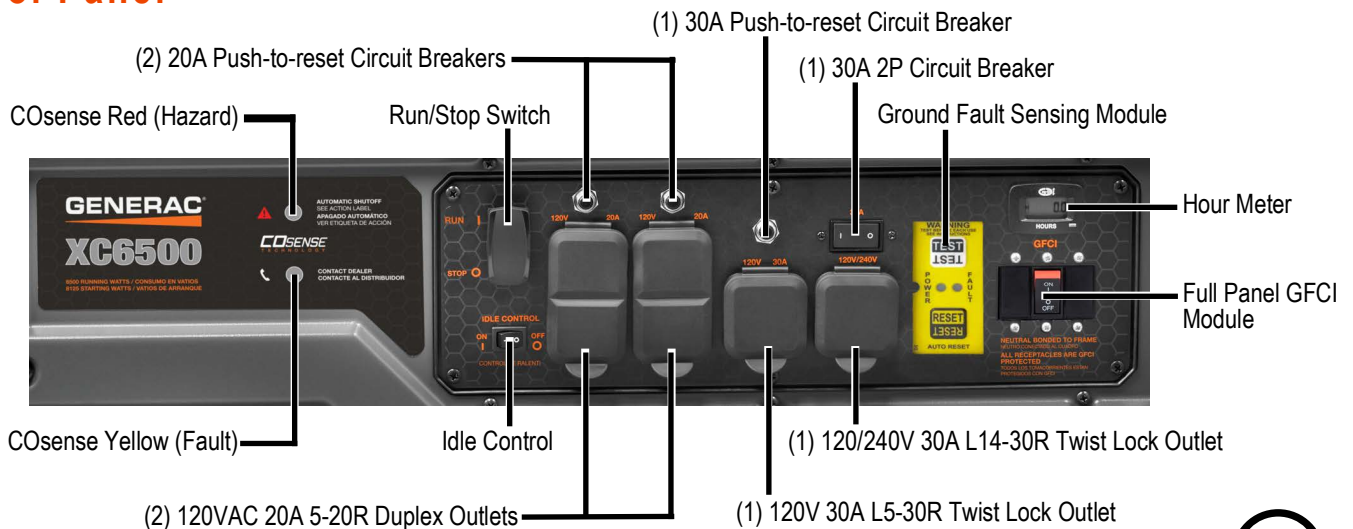

*Assembled in the USA using domestic and foreign parts

XC6500

Specifications

Product Series	XC6500
Model (Configuration)	G0080430 (49-State)
AC Rated Output Running Watts	6500
AC Maximum Output Starting Watts	8125
Rated AC Voltage	120/240 VAC
Rated AC Frequency	60 Hz
Rated 120/240 VAC Amperage	54.2/27.0
Engine Displacement	426cc
Engine Type	Generac G-Force
Engine RPM	3600
Recommended Oil	10W-30 / SAE 30
Lubrication Method	Oil Pump
Automatic Voltage Regulation (AVR)	Yes
Total Harmonic Distortion	<5%
Choke Location	On Engine
Fuel Shut Off	On Fuel Tank
Starting Method	Recoil Pull Start
Low Oil Shutdown	Low Pressure
Neutral Bonded to Ground	Yes
Start Switch Type	Run/Stop

Start Switch Location	On Control Panel
Steel Lifting Pocket	Included
Fuel Gauge	Built-in Tank
Fuel Tank Capacity Gal (L)	8.5 (32)
Run Time at 50% (Hours)	14
Handle Style	Dual Folding/Locking
Grab Bars	Yes
Wheel Type	10" Solid with Steel Hub
Maintenance Kit	Included
Warranty- Commercial	2 Year Limited
Warranty- Residential	3 Year Limited

Dimensions and Weights

Model	
Length in (mm)	34.3 (872)
Width in (mm)	28.6 (727)
Height in (mm)	32.5 (825)
Extended Length in (mm)	46.8 (1188)
Carton Length in (mm)	38.8 (984)
Carton Width in (mm)	23.5 (597)
Carton Height in (mm)	30 (762)
Unit Weight lbs (kg)	243 (110.2)
Shipping Weight lbs (kg)	263 (119.3)

